



FISHMAN[®]

FLUENCE MIKE INEZ LEGACY SERIES SET
INSTALLATION GUIDE

System Requirements

These instructions provide installation options for the Fishman Fluence series of multi-voice pickups, but these instructions are not comprehensive. A skilled electronics technician can simply interpret this overview to create a wide range of custom wiring options. Please consult with your installer for alternate switching and control components or options not specifically detailed in this guide or included with your pickup purchase. Please visit www.fishman.com for additional wiring diagrams.

Installation Warning!

By self-installing and/or misusing this product, you understand and agree that and such uses are high risk activities and, to the extent permitted by law, YOU EXPRESSLY AND VOLUNTARILY ASSUME THE RISK OF DEATH OR OTHER PERSONAL INJURY SUSTAINED WHILE PARTICIPATING IN SUCH ACTIVITIES WHETHER OR NOT CAUSED BY THE NEGLIGENCE OR ANY OTHER FAULT of Fishman, including but not limited to equipment malfunction from whatever cause, or any other fault of Fishman. Additionally, you agree to indemnify, defend and hold Fishman harmless from any third party claims arising from such activities.

Getting Started

1. Determine the rotary controls (Volume, Tone, etc.) and switches to be used in your installation, including those included with your purchase. Test fit the components to make sure that each will fit in the allocated locations or modify the instrument until the fit is correct and all controls can be located without issue. Fishman Fluence Pickups are active and require 25K audio taper potentiometers.

2. Fishman Fluence multi-voice pickups require a 9V power supply.

- If using a standard 9V battery, test fit cavity locations for simple installations or consider installing an externally accessible battery compartment (available separately.) Note that it is important the battery is not allowed to short contacts between controls in the instrument.
- If using a separately purchased Fishman rechargeable battery, refer to those instructions to complete this part of your installation.
- Note that it may be possible to combine other active pickups with Fishman Fluence pickups, but all pickups will need to use the same 9V power source. Only active pickup combinations are supported.

3. The various pickup voicing options are easily activated by connecting the corresponding control wires to Ground. Any of these options can be made switch selectable using the included push-pull pots or other preferred switches. They can also be permanently wired by either connecting to Ground or leaving "open" (unconnected). See the "Connection Points and Functions" section for helpful details.

4. Review your planned scheme for errors, complete the soldering, mount and secure all your components, and test your completed installation before assembly. Consider a popular wiring option as shown on the reverse side of this guide or visit www.fishman.com for additional wiring diagrams.

Mike Inez Signature:

Voice – 1: (2.6kHz, 40Hz) From Ozzy to Alice and beyond, this is THE tone.

Voice – 2 Mid Contour: (760Hz, 80Hz) For all of Mike's warmer, more vintage tones.

Fluence Soapbar (bridge):

Voice – 1: (2kHz) Classic, Fat, and Round tone, use for all vintage type sounds, without excess high end string noise and with a fat low end that moves a lot of air.

Voice – 2 Mid Contour: (7kHz w/500Hz mid-scoop) The most extreme high fidelity, clarity, percussiveness, and articulation you've ever experienced in a magnetic bass pickup. Equally suitable for slapping and funk as it is the most aggressive metal.

Voice – 2 Mid Flat: (7kHz w/mid-flat) The same fidelity, clarity, and articulation as Voice 2 but with the midrange opened up for a more vocal quality, especially suitable for Modern Jazz Bass tones in single coil mode

(Single Coil mode can be used with any of the three voices)



Fluence Bass – Connection Points & Functions

1. Voice-2 Select Wire - To select Voice-2, connect this pin to ground through a switch contact or permanently by soldering it to any ground.

This pin is an electronically controlled switch and has no signal on it. It can share a switch contact with other voice select wires without interaction.

2. Voice-1 Limiter Off Pin - This pin is intended for production testing and not utilized for installation. Voice-1 has a subtle soft limiter that is active near the upper limits of the dynamic range. This feature is designed to create a certain feel when pushed hard. Connecting this pin to ground will deactivate the Voice-1 limiter.

3. 8k Output Impedance Wire - This pin sets the series output impedance to 8k-ohm when grounded. This is used when combining with a 2nd SB-1 Fluence bass pickup through a 25k blend control. The 8k source impedance produces a smoother taper on the blend control.

If the pin is left unconnected, the default output impedance is 2k-ohm, typical of most Fluence pickups.

4. +9-18V - This is the + dc power input pin. Fluence pickups are designed to have a wide dynamic range running from a 9V supply, however they are 18V compatible for instruments already set up that way.

5. Output - The main output pin has a 2k or 8k-ohm (selectable) output impedance and is suitable for driving low impedance volume, blend, and tone pots, typically 25k. instruments already set up that way.

Wiring diagrams are available at Fishman.com

FISHMAN FLUENCE™

Mike Inez - Legacy Bass Pickup

Volume w 2-Band Dual Concentric EQ - Pull Volume for Voice-2

Neck Pickup
Mike Inez Legacy

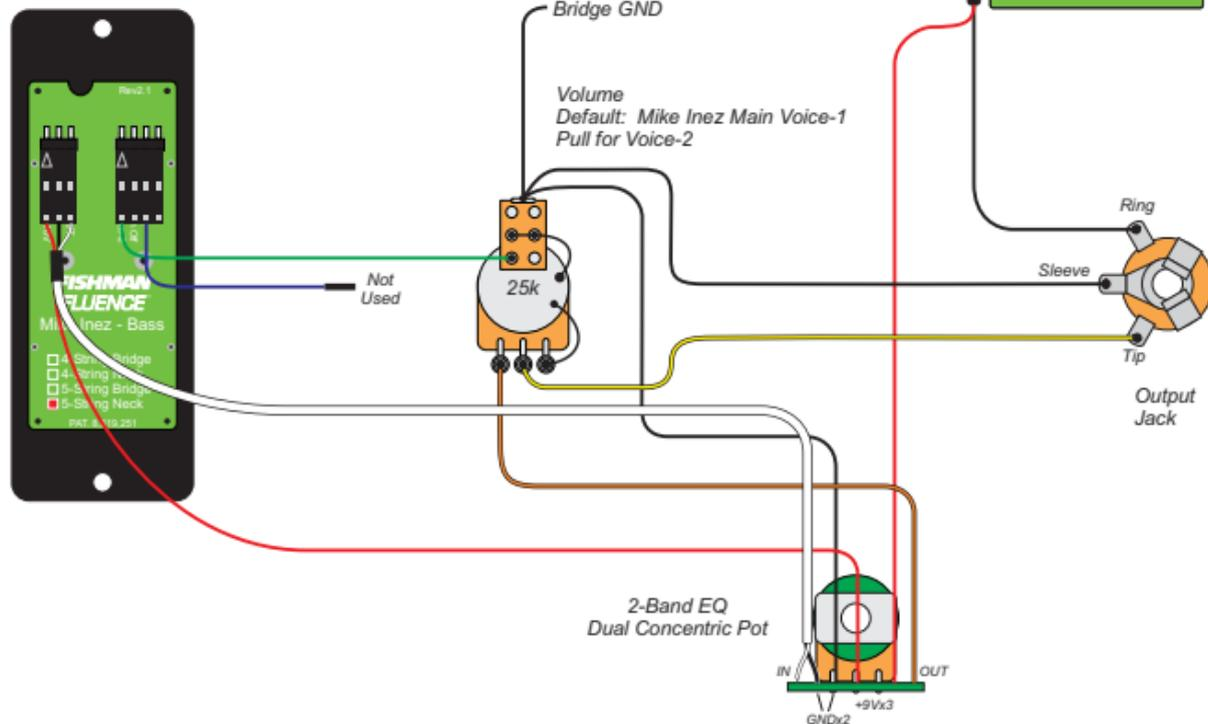

FISHMAN FLUENCE™

Mike Inez - Legacy Bass Pickup

Volume w 2-Band EQ - Pull Volume for Voice-2

Neck Pickup
Mike Inez Legacy

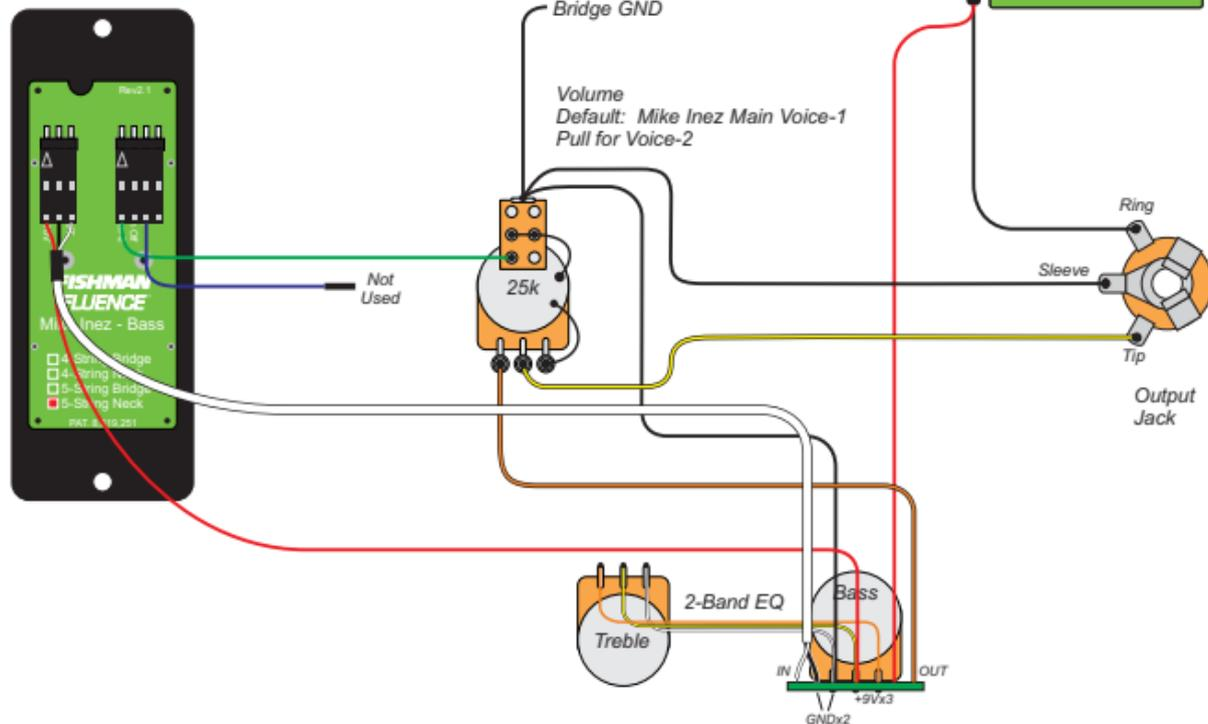

FISHMAN FLUENCE™

Mike Inez - Legacy Bass Pickup Set

Volume & Blend Control w 2-Band EQ - Pull Volume for Mike Inez Alt. Voice & Bridge Voice-1

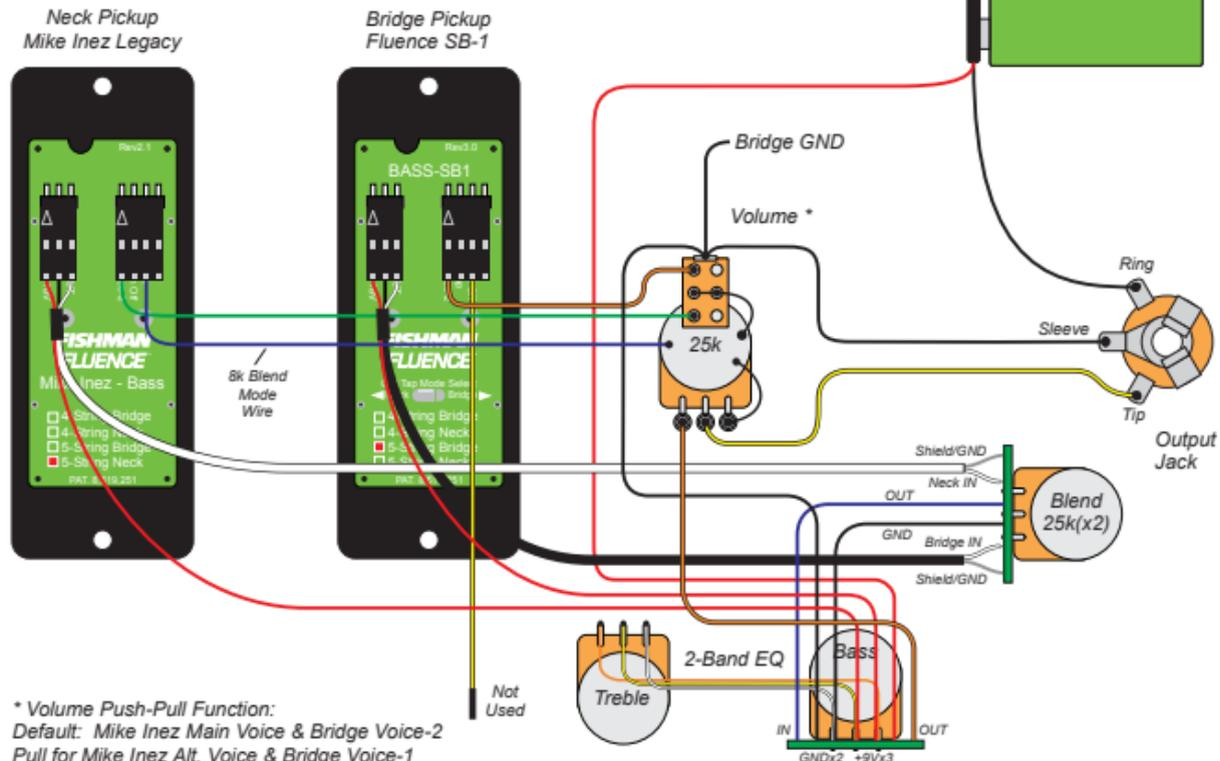

* Volume Push-Pull Function:
Default: Mike Inez Main Voice & Bridge Voice-2
Pull for Mike Inez Alt. Voice & Bridge Voice-1

FISHMAN FLUENCE™

Mike Inez - Legacy Bass Pickup Set

Volume & Blend Control w 2-Band EQ - Mini Toggle Voice Select

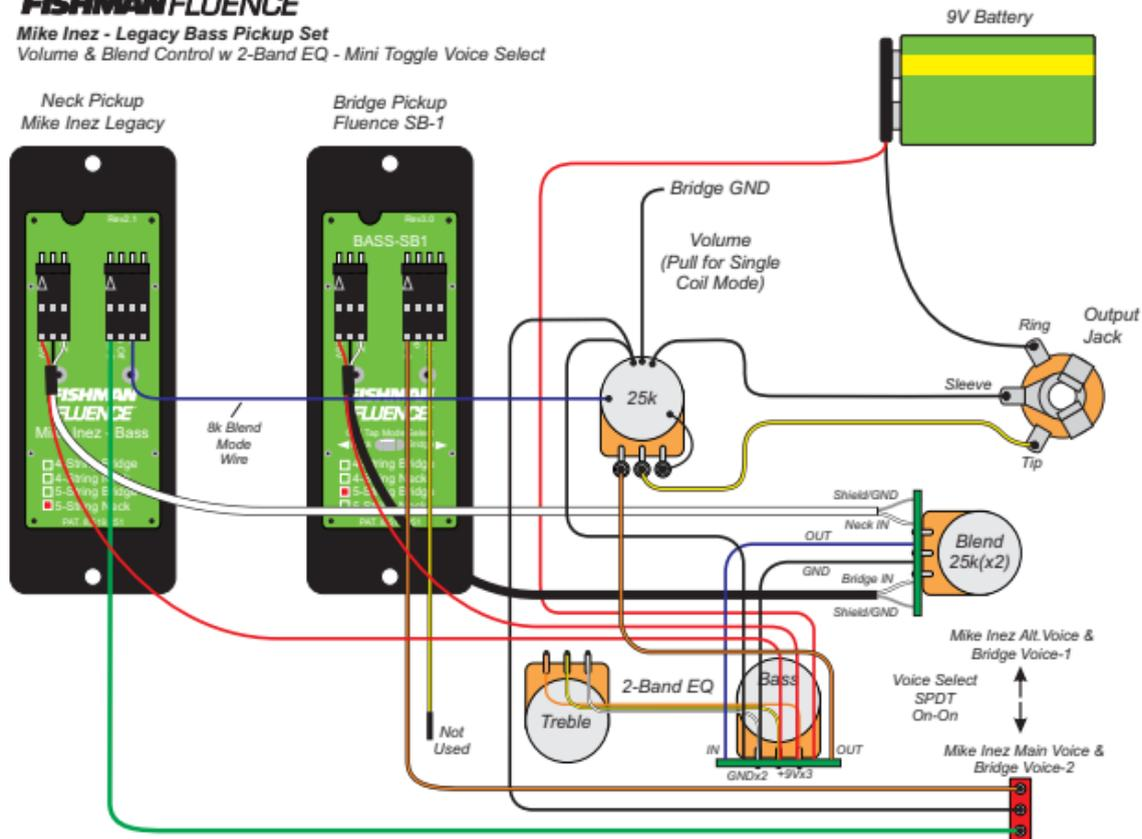



PRODUCT PAGE & INSTALL GUIDE

FISHMAN[®]