

www.fishman.com

FISHMAN

**USER GUIDE
AURA® PRO RETAIL**

Welcome

Thank you for making Fishman a part of your acoustic experience. We are proud to offer you the finest acoustic amplification products available; high-quality professional-grade tools to empower you to sound your very best. We are confident Aura Pro will both enhance and inspire your music making.

Image Chart

Once you upload Images into your Aura Pro, use this chart for quick reference.

Image #	Instrument Name	Microphone	Mic Distance
----------------	------------------------	-------------------	---------------------

1			
----------	--	--	--

2			
----------	--	--	--

3			
----------	--	--	--

4			
----------	--	--	--

Fundamentals

To experience the benefits of Aura, install the Aura Gallery CD on your computer then upload Images into the Aura Pro preamp. Flip open the preamp and connect the included USB cable to the side of the preamp.

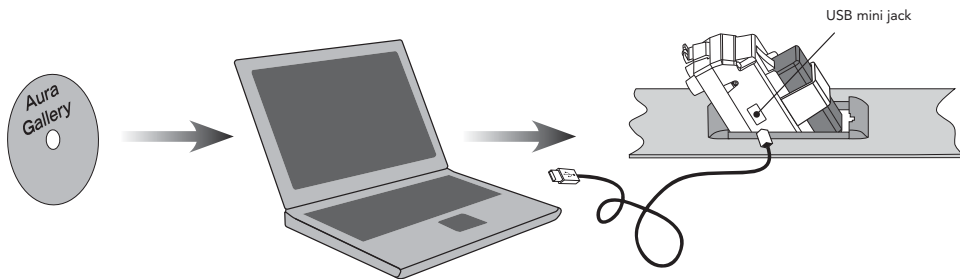

Quick Start

Before you begin, set the controls as shown:

- 1. Plug in** • Use a ¼-inch instrument cable.
- 2. Tune up** • Set Play/Edit switch to Play. Press Tuner button. When engaged, Tuner mutes the output. Press again to exit Tuner.
- 3. Select an Image** • Raise the Volume and use the Image switch to browse the Images.
- 4. Blend in pickup** • Turn Blend control left to mix pickup with Image.

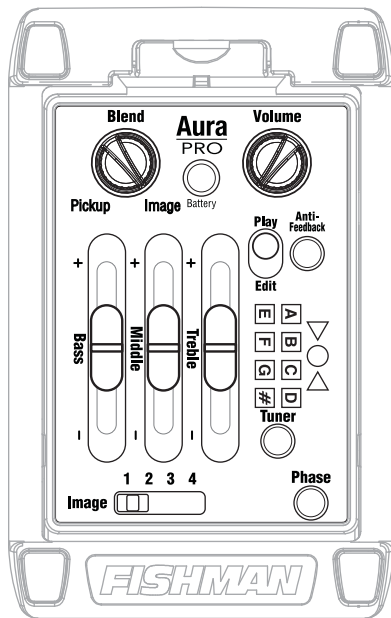

5. Pickup tone • Set Play/Edit switch to Play and adjust tone controls.

6. Image tone • Set Play/Edit switch to Edit and adjust tone controls. Move switch back to Play to lock Image tone.

7. Control Feedback

- If feedback occurs, push Phase switch. If feedback recurs when you change your location, press switch again.
- Push Anti-Feedback button once. Turn up Volume, then either dampen the strings while tapping the body, or play the troublesome note until the filter eliminates feedback.

Note: Aura Pro is a programmable preamplifier. To restore factory defaults, see page 16.

Power

Plug in the guitar, and the Aura Pro switches on. To conserve the battery, remove the instrument cable from the guitar when the system is not in use. The LEDs in the tuner display flash once at power-up to tell you the preamp is on.

Low Battery Indicator

When the "Battery" LED flashes once every three seconds, you have approximately 1.5 hours before the battery is exhausted. Change it at the next opportunity. When the "Battery" LED flashes every half a second, the battery is practically spent and should be changed immediately.

Tuner

With the Play/Edit switch set to Play, depress the Tuner button to turn the circuit on and off. This digital chromatic tuner accommodates all standard and alternate tunings and mutes the output when engaged. It can also be activated without an instrument cable, in which case it will turn itself off after 90 seconds.

Note that the tuner is calibrated to A = 440.

Flashes when Anti-Feedback filter
is ready to measure feedback

pitch is raised 1/2 step
Flashes in Edit mode

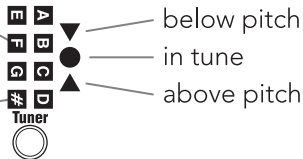

Controls

Image

Your Aura Pro can be loaded with four Images that you select using the Aura Image Gallery software.

Volume

For the cleanest noise-free sound, set the Volume as high as possible without causing your amp or mixer to distort.

Blend

Use the Blend slider to set the balance between the pickup and the Image.

Tone Controls & Play/Edit Switch

The Play/Edit switch lets you EQ the pickup and Image(s) independently.

Pickup EQ

Move the Play/Edit switch to Play and adjust the Bass, Mid and Treble controls. Switch to Edit and the preamp retains the pickup EQ settings, disengages the pickup tone controls and enables Image EQ. Return to Play and the preamp holds the pickup EQ settings until the Bass, Mid or Treble controls are moved (regardless of the current position of the controls).

Programmable Image EQ

To EQ an Image, move the Play/Edit switch to Edit. The “#” LED flashes to indicate Edit mode. Move the Blend slider to Aura, select an Image and adjust the tone controls. You can program EQ for each of the four Images: simply select another Image and adjust the controls. Switch to Play and the preamp retains the Image EQ settings, disengages the Image tone controls and enables pickup EQ. Go back to Edit and the preamp holds the Image EQ settings until the Bass, Mid or Treble controls are moved (regardless of the current position of the controls).

Phase Switches

Phase (global)

Use the Phase switch to improve bass response at low volume and suppress feedback at high volume. Push the Phase switch in and out and leave it in the position most pleasing to your ear. If feedback occurs, push the switch again.

Relative Phase (pickup phase)

To change the character of your blended sound, you may wish to change the phase of the pickup relative to the Image. There is no “best” position for Relative Phase and where you set it is a matter of personal taste.

1. Center Blend slider and switch to Edit. The “#” LED flashes to indicate Edit mode.
2. Push the Tuner button to toggle the relative pickup phase. ► = default.
3. To exit Relative Phase, move the Play/Edit switch to Play.

You can program different Relative Phase settings for each of the four Images. Select a different Image and repeat above procedure.

Anti-Feedback

Use this search-and-destroy Anti-Feedback filter in addition to the Phase switch.

1. Push Anti-Feedback button once. The letter "F" in tuner display will flash.
2. Turn up Volume, then either dampen the strings while tapping the body or play the troublesome note until the feedback begins. The automatic filter will identify and eliminate the feedback. The circuit will hold this offending frequency in memory until you push the Measure button again.

To turn the circuit off, push and hold the Anti-Feedback button for five seconds.

Battery Replacement

Pull the small tab at the top of the Aura Pro toward you. The body of the preamp will swing out, revealing the battery compartment. Observe the polarity marks on the battery compartment and install a fresh 9V battery. See page 15. We recommend a lithium battery for extended battery life.

Input Trim and VU Meter

Adjust this set-and-forget control to accommodate the dynamics of your playing style. When you set Input Trim to the optimum level, you can play strongly without distortion and play quietly without hiss.

To Set the Input Trim:

- Unplug the guitar and pull the small tab at the top of the Aura Pro toward you. Locate the small circular potentiometer on the right side of the preamp.
- To turn on the VU meter, move the Edit/Play switch to Play and plug in the guitar while holding the Anti-Feedback button for two seconds; release when the “G” lights. The pitch LEDs (two arrows and a circle) will now display the input level of the preamp.
- Play the instrument strongly and watch the LED display. Use a small flat-head screwdriver to raise or lower the trim control so all three LEDs flash occasionally with hard strumming.
- To exit the VU meter, push the Tuner button.

Input Trim

Battery Compartment

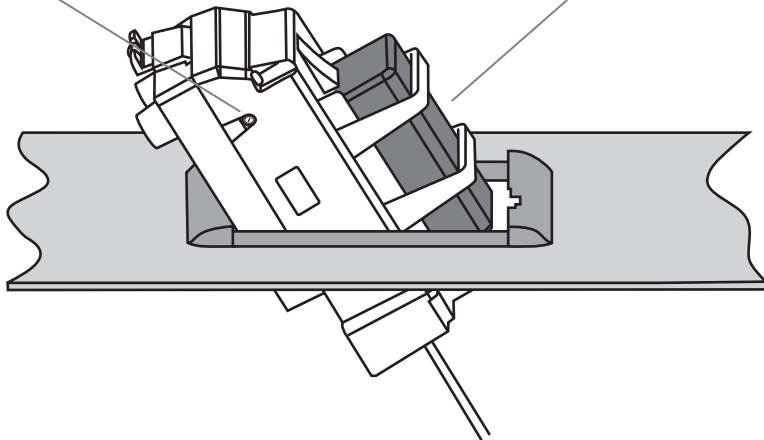

Restore Factory Defaults

1. Unplug the guitar and move the tone controls to the center detent position.
2. Move the Edit/Play switch to Play.
3. Hold the Anti-Feedback button, plug in the guitar and press the Tuner button within two seconds.
4. When the Tuner "D" LED flashes, release the buttons. Factory Reset is complete when the "D" stops flashing and Aura Pro returns to normal operation.

Defaults:

- EQ for all four Images reverts to flat.
- Relative Phase settings return to default state.
- Anti-Feedback frequency is reset to 100Hz.

Electrical Specifications

Digital Signal Path:

A/D, D/A conversion:

24-bit

Signal Processing:

32-bit

Typical in-use current consumption @ 9VDC:

18mA

Typical 9V lithium battery life:

54 hours

Typical 9V alkaline battery life:

27 hours

Nominal output impedance:

1k Ohm

Recommended load impedance:

10k Ohm and up

Input Trim gain range:

-6dB to +6dB

Maximum output level (onset of clipping):

+5dBV

Baseline noise:

-92dBV

Dynamic Range:

97dB

Bass control:

± 12 dB @ 90Hz

Midrange control:

± 12 dB @ 1kHz

Treble control:

± 12 dB @ 6kHz

Anti-Feedback: cut depth:

13.5dB

The specifications and information in this manual are subject to change without notice.

FISHMAN

www.fishman.com