

www.fishman.com

FISHMAN

**USER GUIDE
ONBOARD AURA™**

Welcome

Thank you for making Fishman a part of your acoustic experience. We are proud to offer you the finest acoustic amplification products available; high-quality professional-grade tools to empower you to sound your very best. We are confident Onboard Aura will both enhance and inspire your music making.

Quick Start

Before you begin, set the controls as shown:

- 1. Plug in** • Use a ¼-inch instrument cable.
- 2. Tune up** • Set **Play/Edit** switch to **Play**. Press **Tuner** button. When engaged, Tuner mutes the output. Press again to exit Tuner.
- 3. Select an Image** • Raise the **Volume** and use the **Image Select** knob to browse the Images.
- 4. Blend in pickup** • Lower **Blend** slider to mix pickup with Image.

4

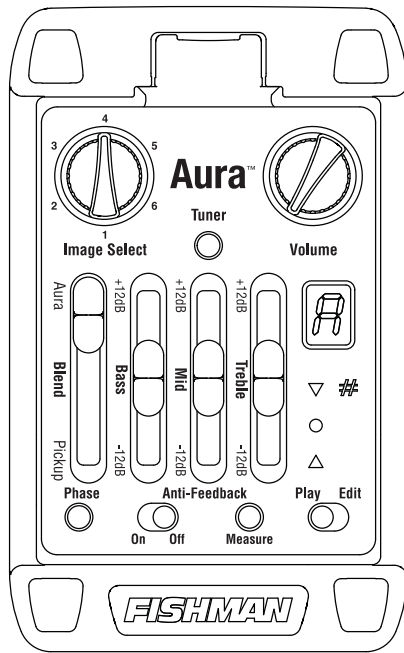

5. Pickup tone • Set **Play/Edit** switch to **Play** and adjust tone controls.

6. Image tone • Set **Play/Edit** switch to **Edit** and adjust tone controls. Move switch back to **Play** to lock Image tone.

7. Control Feedback

- If feedback occurs, push **Phase** switch. If feedback recurs when you change your location, press switch again.
- Turn **Anti-Feedback** switch **On** and push Measure button once. Turn up **Volume**, then either dampen the strings while tapping the body, or play the troublesome note until the filter eliminates feedback.

Note: Onboard Aura is a programmable preamplifier. To restore factory defaults, see page 14.

5

Power

Plug in the guitar, and the Onboard Aura switches on. To conserve the battery, remove the instrument cable from the guitar when the system is not in use.

The LEDs in the tuner display flash once at power-up to tell you the preamp is on.

Low Battery Indicator

When the tuner flashes an "L" once every three seconds, you have approximately 1.5 hours before the battery is exhausted. Change it at the next opportunity. When the tuner flashes an "L" every half a second the battery is practically spent and should be changed immediately.

Tuner

With the **Play/Edit** switch set to **Play**, depress the **Tuner** button to turn the circuit on and off. This digital chromatic tuner accommodates all standard and alternate tunings and can be activated without an instrument cable. When engaged, the tuner mutes the output and will turn itself off after 45 seconds.

Note that the tuner is calibrated to A = 440.



below pitch — ▼ # — pitch is raised ½ step
in tune — ● flashes in edit mode
above pitch — ▲

Controls

Image Select

Your Onboard Aura is factory loaded with six Images created especially for this instrument. Each Image corresponds to a different microphone type and position. Contact the guitar's manufacturer to identify the microphone associated with each Image.

Volume

For the cleanest noise-free sound, set **Volume** as high as possible without causing your amp or mixer to distort.

Blend

Use the **Blend** slider to set the balance between the pickup and the Image.

Tone Controls & Play/Edit Switch

The **Play/Edit** switch lets you EQ the pickup and Image(s) independently.

Pickup EQ

Move the **Play/Edit** switch to **Play** and adjust the **Bass**, **Mid** and **Treble** controls. Switch to **Edit** and the preamp retains the pickup EQ settings, disengages the pickup tone controls and enables Image EQ. Return to **Play** and the preamp holds the pickup EQ settings until the **Bass**, **Mid** or **Treble** controls are moved (regardless of the current position of the controls).

Programmable Image EQ

To EQ an Image, move the **Play/Edit** switch to **Edit**. The “#” LED flashes to indicate **Edit** mode. Move the **Blend** slider to **Aura**, select an Image and adjust the tone controls. You can program EQ for each of the six Images: simply select another Image and adjust the controls. Switch to **Play** and the preamp retains the Image EQ settings, disengages the Image tone controls and enables pickup EQ. Go back to **Edit** and the preamp holds the Image EQ settings until the **Bass**, **Mid** or **Treble** controls are moved (regardless of the current position of the controls).

Phase Switches

Phase (global)

Use the **Phase** switch to improve bass response at low volume and suppress feedback at high volume. Push the **Phase** switch in and out and leave it in the position most pleasing to your ear. If feedback occurs, push the switch again.

Relative Phase (pickup phase)

To change the character of your blended sound, you may wish to change the phase of the pickup relative to the Image. There is no “best” position for Relative Phase and where you set it is a matter of personal taste.

1. Center **Blend** slider & switch to **Edit**. The “#” LED flashes to indicate **Edit** mode.
2. Push the **Tuner** button to toggle the relative pickup phase. ► = default.
3. To exit Relative Phase, move the **Play/Edit** switch to **Play**.

You can program different Relative Phase settings for each of the six Images. Select a different Image and repeat above procedure.

Anti-Feedback

Use this search-and-destroy Anti-Feedback filter in addition to the Phase switch.

1. Move **Anti-Feedback** switch left to **On** position and push the **Measure** button once. The tuner display will animate to indicate it is searching for feedback.
2. Turn up **Volume**, then either dampen the strings while tapping the body or play the troublesome note until the feedback begins. The filter will automatically identify and eliminate the feedback. The circuit will hold this offending frequency in memory until you push the **Measure** button again.

Battery Replacement

Pull the small tab at the top of the Onboard Aura toward you. The body of the preamp will swing out, revealing the battery compartment. Observe the polarity marks on the battery compartment and install a fresh 9V battery. We recommend a lithium battery for extended battery life.

Input Trim and VU Meter

Adjust this set-and-forget control to accommodate the dynamics of your playing style. When you set Input Trim to the optimum level, you can play strongly without distortion and play quietly without hiss.

To Set the Input Trim:

- Unplug the guitar and pull the small tab at the top of the Onboard Aura toward you. Locate the small circular potentiometer on the right side of the preamp.
- To turn on the VU meter, move the **Edit/Play** switch to **Play** and plug in the guitar while holding the **Measure** button for two seconds. Release the **Measure** button when a “**U**” is shown in the tuner display. The pitch LEDs (two arrows and a circle) will now display the input level.
- Play the instrument strongly and watch the LED display. Use a small flat-head screwdriver to raise or lower the trim control so all three LEDs flash occasionally with hard strumming.
- To exit the VU meter, push the **Tuner** button.

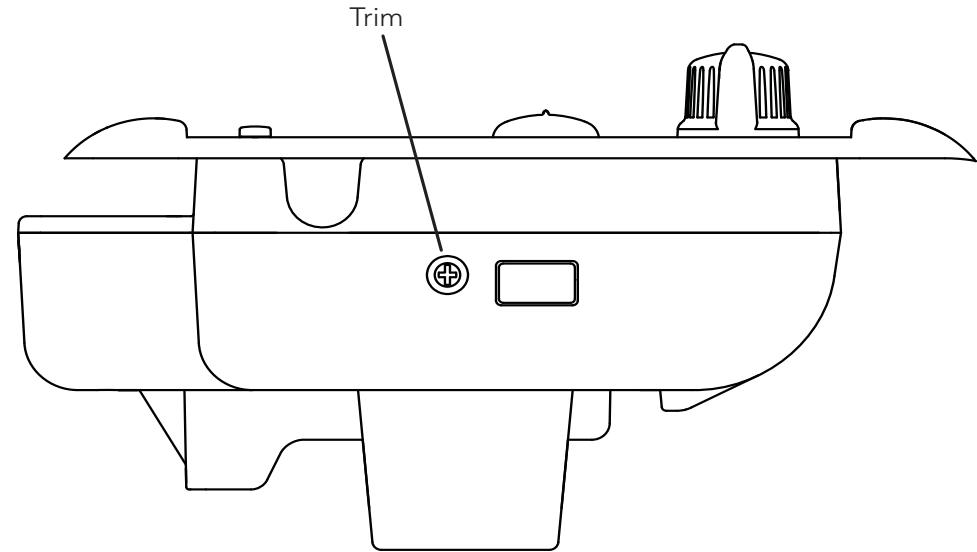

Restore Factory Defaults

1. Unplug the guitar, move the tone controls to the center detent position.
2. Move the **Edit/Play** switch to **Play**.
3. Hold the **Measure** button, plug in the guitar and press the **Tuner** button within two seconds.
4. When the tuner display flashes an "F," release the buttons. The factory reset is complete when the "F" stops flashing and the unit returns to normal operation.

Defaults:

- EQ for all six Images reverts to flat.
- Relative Phase settings return to default state.
- Anti-Feedback frequency is reset to 100Hz.

Electrical Specifications

Digital Signal Path:	
A/D, D/A conversion:	24-bit
Signal Processing:	32-bit
Typical in-use current consumption @ 9VDC:	18mA
Typical 9V lithium battery life:	54 hours
Typical 9V alkaline battery life:	27 hours
Nominal output impedance:	1k Ohm
Recommended load impedance:	10k Ohm and up
Input Trim gain range:	-6dB to +6dB
Maximum output level (onset of clipping):	+5dBV
Baseline noise:	-92dBV
Dynamic Range:	97dB
Bass control:	±12dB @ 70Hz
Midrange control:	±12dB @ 1kHz
Treble control:	±12dB @ 6.5kHz
Anti-Feedback: cut depth:	13.5dB

All specifications subject to change without notice.

FISHMAN

www.fishman.com

513-000-033 Rev B 9-08