

Owner's Manual

Loudbox Pro™ | Acoustic Instrument Amplifier



Read Me!

Take a few minutes to read through this manual before you power-up the Loudbox Pro. To jump in immediately, start with the **Important Safety Instructions** and the **Getting Started** sections. While this information will get you on your way, it is not considered a substitute for reading the entire manual.



CAUTION
Risk of electric shock.
Do not open.



No user serviceable parts inside.
Refer servicing to qualified personnel.
Do not expose to rain or moisture.



Wherever this symbol appears, it alerts you to the presence of uninsulated dangerous voltage inside the enclosure that may be sufficient to constitute a risk of shock.



Whenever this symbol appears, it alerts you to the presence of important operating and maintenance (servicing) instructions in the user's manual for this amplifier.

Important Safety Instructions

To ensure your personal safety and the safety of others, operate this apparatus only after reading these instructions and heeding the warnings listed below.

1. Read these instructions.
2. Keep these instructions.
3. Heed all warnings.
4. Follow all instructions.
5. Do not use this apparatus near water.
6. Clean only with a dry cloth.
7. Do not block the ventilation openings. Install in accordance with the manufacturer's instructions.
8. Do not install near any heat sources such as radiators, heat registers, stoves or other apparatus (including amplifiers) that produce heat.
9. Do not defeat the safety purpose of the polarized or grounding-type plug. A polarized plug has two blades with one wider than the other. A grounding-type plug has two blades and a third grounding prong. The wide blade or the third prong are provided for your safety. If the provided plug does not fit into your outlet, consult an electrician for replacement of the obsolete outlet.
10. Protect the power cord from being walked on or pinched, particularly at the plugs, convenience receptacles and the point where they exit from the apparatus.

11. Use only attachments/accessories specified by the manufacturer.
12. Use only with a cart, stand, tripod, bracket or table specified by the manufacturer, or sold with the apparatus. When a cart is used, use caution when moving the cart/apparatus combination to avoid injury from tip-over.
13. Unplug this apparatus during lightning storms or when unused for long periods of time.
14. Refer all servicing to qualified service personnel. Servicing is required when the apparatus has been damaged in any way, such as a power-supply cord or plug is damaged, liquid has been spilled or objects have fallen into the apparatus, the apparatus has been exposed to rain or moisture, does not operate normally, or has been dropped.



Do not expose the apparatus to dripping or splashing liquids and do not place objects filled with liquids (such as a beverage container or a vase) on the apparatus

Warning

To reduce the risk of fire or electric shock, do not expose this apparatus to rain or moisture.

Hear This!

The Loudbox amplifier is capable of cleanly reproducing the sound of your instrument at very high volume levels. Prolonged repeated exposure to high sound pressure levels (SPLs) without protection can cause permanent hearing loss. OSHA has set guidelines and specified permissible sound exposure limits for those who work in high SPL environments.

Permissible Noise Exposures

Duration per day, hours	Sound level dBA slow response
8	90
6	92
4	95
3	97
2	100
1 1/2	102
1	105
1/2	110
1/4 or less	115

To ensure against permanent hearing loss, wear hearing protection when you perform with amplification.

Welcome...

...and thank you for choosing the **Fishman Loudbox Pro!** We recognize that as an acoustic musician, you expect your amplifier to seamlessly reproduce the sound you have worked hard to cultivate. We share your expectations and our job (our obsession really) is to meet and exceed them. Plug in your Loudbox Pro and be prepared for acoustic fireworks; you have before you what is probably the most potent and transparent acoustic amplifier ever built! If you have any questions or comments, please contact us through the Service and Support section of our website at www.fishman.com.

Save Your Packing Materials

The box and packing materials for the Loudbox Pro were specially designed to protect the amplifier during shipping. Save all this stuff in case you ever need to re-ship the Loudbox Pro.

Getting Started

The information in this section is comprised of basic setup tips intended to help get you started. To operate the Loudbox Pro safely, please read the entire manual, especially the Important Safety Information above.

1. Set the power switch to off and connect the power cord.
If your amplifier has an operating voltage of 120V, plug the provided AC line cord into the back of the amplifier.
If your amplifier operates at 240V, you must supply your own detachable power cord. The cord you supply must have an IEC-style 320 connector at one end, and a male AC plug appropriate for your area at the other.
2. Plug the Loudbox Pro into an electrical outlet with the appropriate AC voltage.



NOTE: Do not defeat the ground prong on the AC cable; the safe operation of this amplifier depends on a proper ground connection.



3. Push in the Mute switch and turn on the Power switch.
4. Connect your instrument to the Channel 1 input with a shielded 1/4" cable.
5. Set the Channel 1 Gain to 7 o'clock (off).
6. Set the controls as illustrated below.

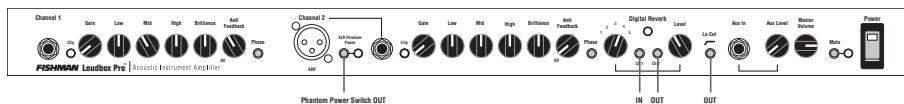

7. Disengage the Mute switch and slowly raise the Channel 1 Gain until you reach a comfortable level. Lower the Gain if the red Clip LED lights up when you play.

Description

The tri-amped, 600-watt, two-channel Loudbox Pro features a 12" woofer driven by a 380-watt power amp. The 6" polypropylene mid driver is pushed by 160 watts and the three 1" soft-dome neodymium tweeters also have their own 60-watt amplifier. These speaker components have been painstakingly designed for high power handling and a smooth, flat acoustic response. Each component is housed in its own sealed enclosure and tuned precisely for acoustic stringed instruments. For close onstage monitoring, an integrated kickstand allows you to tilt the amp back as much as 70 degrees.

Our decision to use a tri-amped, three-way speaker system was driven entirely by our quest for amplified clarity and sheer volume. Most acoustic amplifiers on the market are severely underpowered and just don't have the quality components and/or the horsepower to honestly reproduce acoustic instruments at concert levels. To achieve the sound quality and power levels we were looking for, a traditional power amplifier and two-way speaker system just couldn't cut it; we'd sacrifice the system's response or we would over-burden the drivers. Once we added a midrange driver and three power amps to the equation, all these problems evaporated.

Taking a cue from commercial sound reinforcement systems, the three power amplifiers that drive the Loudbox Pro deliver cleaner, less distorted sound through the speakers than any acoustic amplifier in its class. The high-efficiency paper-cone woofer pumps out the bass, the polypropylene midrange driver handles the crucial mid frequencies and three soft-dome neodymium tweeters top off the treble.

The tweeters in the Loudbox Pro are identical to those used in the best studio mastering monitors; they produce a silky smooth treble that is perfect for acoustic instruments. With three of these tweeters, you get great dispersion and high SPLs, without the unpleasant "honk" of high-frequency compression drivers found in many other acoustic amplifiers.

The two-channel Loudbox Pro features ultra-high impedance instrument inputs with EQ sections that include bass, midrange, treble and brilliance controls. Loudbox Pro has a greater than 122 dB SPL rating, so the big thrills with this amp come when you step on the gas and feel the surge of power. Fighting acoustic feedback is straightforward with the Loudbox Pro's notch filters and phase switches. A sophisticated digital reverb with five useful settings can be assigned to either (or both) channel(s). A mute switch, dual effects loops, and an XLR output with selectable pre/post EQ round out the features.



Front Panel - Channel 1 (instrument channel)

Input

This input has a very wide operating range. It will accept high- or low-level signals from active or passive pickups.

Clip LED

The Clip LED will flash when the gain level is too high and the signal becomes distorted. If the light comes on when you play, lower the gain until the distortion goes away.

Gain

Use the Gain knob to set the level of the signal for Channel 1. If the red LED flashes when you play, lower the gain until the flashing stops. If Channel 1 is unused, set the Gain to 7 o'clock.

Low

Shelving bass, ± 10 dB @ 100Hz. Boost here to add weight to the sound. In general, boost bass at low volumes and flatten it out (or cut) at higher levels. With the dial set at 12 o'clock, the control is effectively out of the circuit.

Mid

A resonant-style filter, ± 12 dB @ 1.2kHz. This control affects how well the instrument blends in or stands out in the mix. At loud volumes a midrange cut will achieve a more natural sound. With the dial set at 12 o'clock, the control is effectively out of the circuit.

High

Shelving treble, ± 12 dB @ 10kHz. Boost highs to add "air" to the sound of the instrument. With the knob set at 12 o'clock, the control is effectively out of the circuit.

Brilliance

A resonant-style tone circuit, ± 12 dB @ 10kHz. Add presence and "zing" to high frequencies. With the knob set at 12 o'clock, the control is effectively out of the circuit.

Anti-Feedback

A fixed-level, variable-frequency notch filter -14dB @ 20 - 400Hz. If you encounter low-frequency feedback, sweep this control to isolate and eliminate it. Many guitars will benefit with the Anti-Feedback knob set at about 11 o'clock. The Anti-Feedback filter is off at the 7 o'clock position.

Phase

Use the phase switch in conjunction with the Anti-Feedback filter to eliminate acoustic feedback.

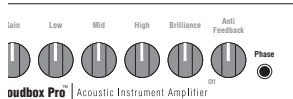
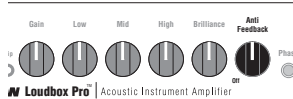
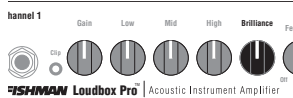
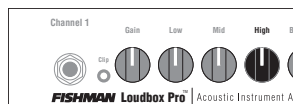
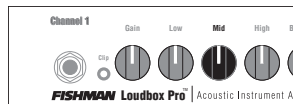
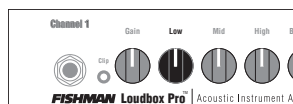
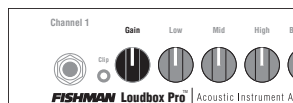
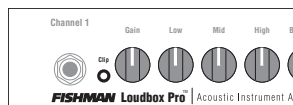
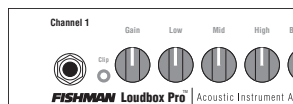

About Acoustic Feedback

Feedback usually occurs in the lowest octave of your instrument, generally with two notes about a half step apart. Like blowing air across a bottle, the lower type of feedback (cavity resonance) starts when the sound pressure coming out of the speakers excites the resonant air chamber inside your instrument. We have found that it is effective to tune out an instrument's cavity resonance feedback with the Anti-Feedback (notch filter) in the Loudbox. For acoustic guitar this occurs at G# on the low E-string, or at about 100Hz. Turn the Anti-Feedback knob to about 11 o'clock to dial out this resonance. Note that the circuit can be effectively defeated by moving the dial to the OFF (7 o'clock) position.

The higher range of feedback (top resonance) usually starts about a half or whole step above cavity resonance of the instrument. Top resonance feedback happens when the sound pressure coming off the speakers excites the resonant frequency of the soundboard of your instrument. For acoustic guitar this occurs at A and above on the low E-string. Push the Phase switch in and out until you find the position that subdues top resonance feedback.

Front Panel - Channel 2 (microphone or instrument channel)

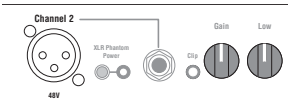

XLR Input

Plug in any balanced dynamic or condenser microphone here. You may also connect an outboard preamp with balanced XLR out to this input. Note that the XLR input will shut off if you attempt to use it simultaneously with the Channel 2 (1/4") input.

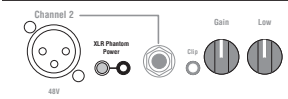

Phantom Power Switch

Provides 48 Volts phantom power to the XLR Input for condenser microphones and phantom-powered preamp/DIs.

Phantom Power FAQs

What devices are safe with 48V phantom power?

- 1 Phantom-powered condenser microphones
- 2 Balanced dynamic microphones
- 3 Many new wireless units
- 4 A preamp/DI designed for phantom-power operation, such as the Fishman Pro-EQ Platinum

What devices are potentially unsafe with 48V phantom power?

- 1 An unbalanced dynamic mic
- 2 A balanced line-level device that is not designed to accept phantom power (ex: some effects processors)
- 3 A balanced wireless receiver that is not designed to accept phantom power. Consult the manufacturer of the wireless unit for compatibility
- 4 An unbalanced signal from an instrument preamp or stompbox

Important Note: Turn off phantom-power if you plug any of the above into the XLR input.

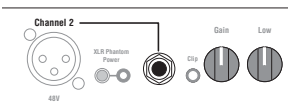

1/4" Input

This input has a very wide operating range. It will accept high- or low-level signals from active or passive pickups. Note that the XLR input will shut off if you attempt to use it simultaneously with the Channel 2 (1/4") input.



Clip LED

The Clip LED will flash when the gain level is too high and the signal becomes distorted. If the light comes on when you play, lower the gain until the distortion goes away. Note that the clip LED monitors both the Channel 2 XLR and 1/4" inputs.

Gain

Use the Gain knob to set the level of the signal for Channel 2. If the red LED flashes when you play, lower the gain until the flashing stops. If Channel 2 is unused, set the Gain to 7 o'clock.

Low

Shelving bass, ± 10 dB @ 100Hz. Boost here to add weight to the sound. In general, boost bass at low volumes and flatten it out (or cut) at higher levels. With the dial set at 12 o'clock, the control is effectively out of the circuit.

Mid

A resonant-style filter, ± 12 dB @ 1.2kHz. This control affects how well the instrument blends in or stands out in the mix. At loud volumes a midrange cut will achieve a more natural sound. With the dial set at 12 o'clock, the control is effectively out of the circuit.

High

Shelving treble, ± 12 dB @ 10kHz. Boost highs to add "air" to the sound of the instrument. With the knob set at 12 o'clock, the control is effectively out of the circuit.

Brilliance

A resonant-style tone circuit, ± 12 dB @ 10kHz. Add presence and "zing" to high frequencies. With the knob set at 12 o'clock, the control is effectively out of the circuit.

Anti-Feedback

A fixed-level, variable-frequency notch filter -14dB @ 20 - 400Hz. If you encounter low-frequency feedback, sweep this control to isolate and eliminate it. Many guitars will benefit with the Anti-Feedback knob set at about 11 o'clock. The Anti Feedback filter is off at the 7 o'clock position.

Phase

Use the phase switch in conjunction with the Anti-Feedback filter to eliminate acoustic feedback. See "About Acoustic Feedback" on page 6.

Digital Reverb

Program

The five program numbers correspond to a graduated sequence of reverbs starting with small room (1) to large hall (5).

Ch 1 Assign

Push in this switch to assign reverb to Channel 1.

Ch 2 Assign

Push in this switch to assign reverb to Channel 2.

Level

Raise the level for a "wetter" sound.

Low Cut Switch

Push in this switch if the sound is too bassy or if low frequency feedback cannot be managed by the Anti-Feedback and phase controls.

Aux Channel

Aux Input

Plug a CD player into this input. The 1/4" TRS Aux Input will mix a stereo signal to mono. You may also plug in a drum machine or keyboard to the Aux input with a standard mono cable.

Aux Level

Use this to control the level of the device you plug into the Aux Input. Note that the Aux channel is independent of the Master Volume and the Mute switch, so you can play pre-recorded music on your breaks. If the Aux channel is unused, set the Aux level to 7 o'clock.

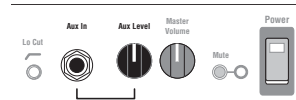
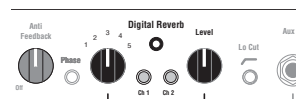
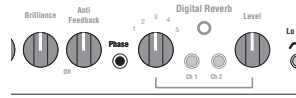
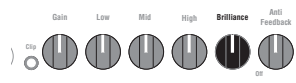
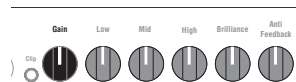

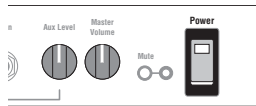
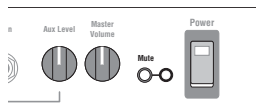
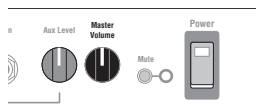

Master Volume

Set the overall level of the Loudbox Pro with the Master Volume. In general put the Master Volume as high as possible (3 o'clock to 5 o'clock) to achieve a clean quiet signal. Because the system can easily produce sound pressure levels in excess of 122dB, we strongly suggest that you wear hearing protection when you play at higher volumes.

Mute

The mute switch shuts off the signals from Channels 1 and 2 to the speakers and the XLR output. The mute does not affect the Aux Channel or the effects sends.

Power

Lower the master volume or engage the mute switch before you turn on the amp to avoid any surprises. Flip the power switch up and it will light, indicating the amp is on.

Rear Panel

AC Power

For 120V amplifiers purchased in the USA, Canada, and Mexico, plug in the supplied detachable AC power cable.

For 240V amplifiers purchased outside the USA and Canada, you must supply your own detachable AC cable. This cable must have an IEC-style 320 connector at one end, and a male AC plug appropriate for your area at the other.

Fuse Holder

The fuse is located within the AC power receptacle on the back of the amp. Access the fuse compartment with a small slotted screwdriver.

For 120V amplifiers purchased in the USA and Canada, replace the fuse with: Littelfuse® type H218005 or equivalent 5 x 20mm, 5A, 250V, time-delay fuse.

For 240V amplifiers purchased outside the USA and Canada, replace the fuse with: Littelfuse® type H21802.5 or equivalent; 5 x 20mm, 2.5A, 250V, time-delay fuse.

Effects Loops

Ch 1 Effects Loop (serial)

Patch an external effect (delay, reverb, chorus) through these jacks. Use a standard 1/4" instrument cable to connect the Ch 1 send to the input of the effect. Connect the Ch 1 return jack to the output of the effect. The loop is located "pre-EQ" and is compatible with battery-operated stompbox-style effects processors.

You may also connect the Ch 1 send jack to an external tuner or to an additional stage amp.

Ch 2 Effects Loop (serial)

Patch an external effect (delay, reverb, chorus) through these jacks. Use a standard 1/4" instrument cable to connect the Ch 2 send to the input of the effect. Connect the Ch2 return jack to the output of the effect. The Ch 2 loop is located "pre-EQ" and is compatible with battery-operated stompbox-style effects processors.

You may also connect the Ch 2 send jack to an external tuner or to an additional stage amp.

XLR Out

Use this balanced output to route your instrument's signal to a mixing console, PA, etc. This output is always ground lifted to reduce ground-loop hum.

XLR Pre/Post EQ switch

Select between a true DI (pre) or an affected XLR output (post EQ).

1. XLR Post EQ

The "Post" setting is useful in live situations, especially if you are mixing from onstage, where you want the "dialed-in" sound from the amp to come through the PA.

2. XLR Pre

You'll find that this true direct or "DI" output produces an uncluttered signal that is exceptional for recording. Set the switch to the "Pre" position when you want a flat DI signal going to the board and you wish to leave it to the soundperson or recording engineer to dial up your tone and effects from the console.

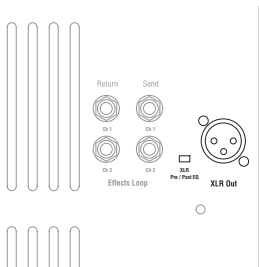
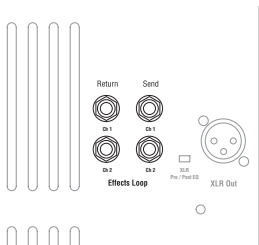
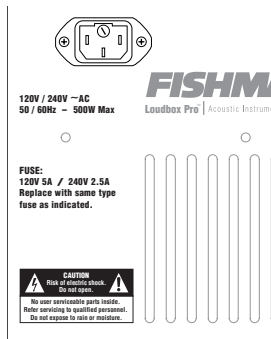

Kickstand

To hear yourself better onstage, use the kickstand to angle the Loudbox Pro back like a wedge-style floor monitor. The kickstand has four click-stops that enable you to tilt the cabinet back to a 40, 50, 60 or 70-degree angle. Squeeze the buttons on the side of the kickstand to unlock the pivot mechanism, and then select the angle that you prefer. Gently tilt the Loudbox Pro back onto the kickstand. The closer you stand to the amp, the more angle you'll need to get the Loudbox pointed at ear level.

Guidelines for selecting the kickstand angle:

40 Degrees

The first click-stop tilts the Loudbox Pro back 40 degrees. Use this when you will be standing more than five feet (1.5 meters) from the amplifier.

50 Degrees

The second click-stop on the kickstand angles the cabinet back 50 degrees, which is useful when you stand about three to five feet (1 to 1.5 meters) from the Loudbox Pro. This angle is also useful when you perform sitting down next to the amplifier.

60 Degrees

The third click-stop angles the cabinet back 60 degrees. Use this position when you stand about one to two feet (30 to 60 cm) from the Loudbox Pro.

70 Degrees

When space is very limited onstage and you must stand directly over the Loudbox Pro, set the kickstand at the fourth click-stop to a 70-degree angle.



Warning: Do not pick the amp up by the kickstand!
For safe operation, use the kickstand only on solid, level ground.

Performance Specifications

Cumulative Rated Power:	600 W rms
Woofer Amp:	380 W rms max single tone sine wave at 100 Hz
Midrange Amp:	160 W rms single tone sine wave at 1 kHz
Tweeter Amp:	60 W rms single tone sine wave at 5 kHz
SPL @ 1 Meter:	≥ 122 dB SPL
Frequency Response:	≥ 4 dB 60 Hz - 20 kHz
Hum and Noise:	≥ -95 dB referred to full output
Power Consumption:	600 W max @ 120 V rms, 60 Hz
Input Impedance:	
Ch 1	10 M Ω / 68 pF
Ch 2, ¼" Jack	10 M Ω / 68 pF
Ch 2 Mic Input	8 K Ω Balanced
Aux Ch	10 K Ω / 10 K Ω
Nominal Input Level:	
Ch 1	- 20 dBv
Ch 2 Inst. Input	- 20 dBv
Ch 2 Mic Input	- 40 dBv
Aux Ch	- 10 dBv
Maximum Recommended Input Level:	
Ch 1	6 dBv
Ch 2, ¼" Jack	6 dBv
Ch 2 Mic XLR Input	-12 dBv
Aux Ch	6 dBv
Phantom Power (Ch2 Only):	
XLR Mic In:	48V / 3.3K Ω Source Impedance
Bass:	± 10 dB @ 100 Hz (Shelving)
Mid:	± 12 dB @ 1.2 kHz (Resonant)
Treble:	± 12 dB @ 10 kHz (Shelving)
Brilliance:	± 12 dB @ 10 kHz (Resonant)
Anti-feedback:	-14 dB @ 20 - 400Hz (Hi - Q Resonant)
Reverb:	Digital, 5 presets, equalized
Effects Send:	
Output Impedance:	2.2 K Ω
Output Voltage:	+ 3 dBv (1.4 V rms max) - 10 dBv Nominal
Effects Return:	
Input Impedance:	20 K Ω
Input Voltage:	+ 3 dBv (1.4 V rms max) - 10 dBv Nominal
XLR Out :	
Output Impedance:	600 Ω
+ 3 dBv balanced	
Phantom-power tolerant	
Crossover:	400 Hz, 3 kHz (Tri-amplified with electronic crossover) 4th Order VCVS Implementation
Speaker System:	
Woofer:	12" treated paper cone
Midrange:	6" polypropylene cone
Tweeters:	3 x 1" soft dome, rare earth magnets, Ferro fluid-cooled
	Woofer and midrange installed in separate isolated and damped compartments
Baffle angles with kickstand:	40, 50, 60, and 70 degrees
Dimensions:	19 ¼" (49cm) H x 25" (63.5cm) W x 11.75" (29.8cm) D
Weight:	77 lbs (35 kg)

Because we continually improve our products, the specifications and information in this manual are subject to change without notice.

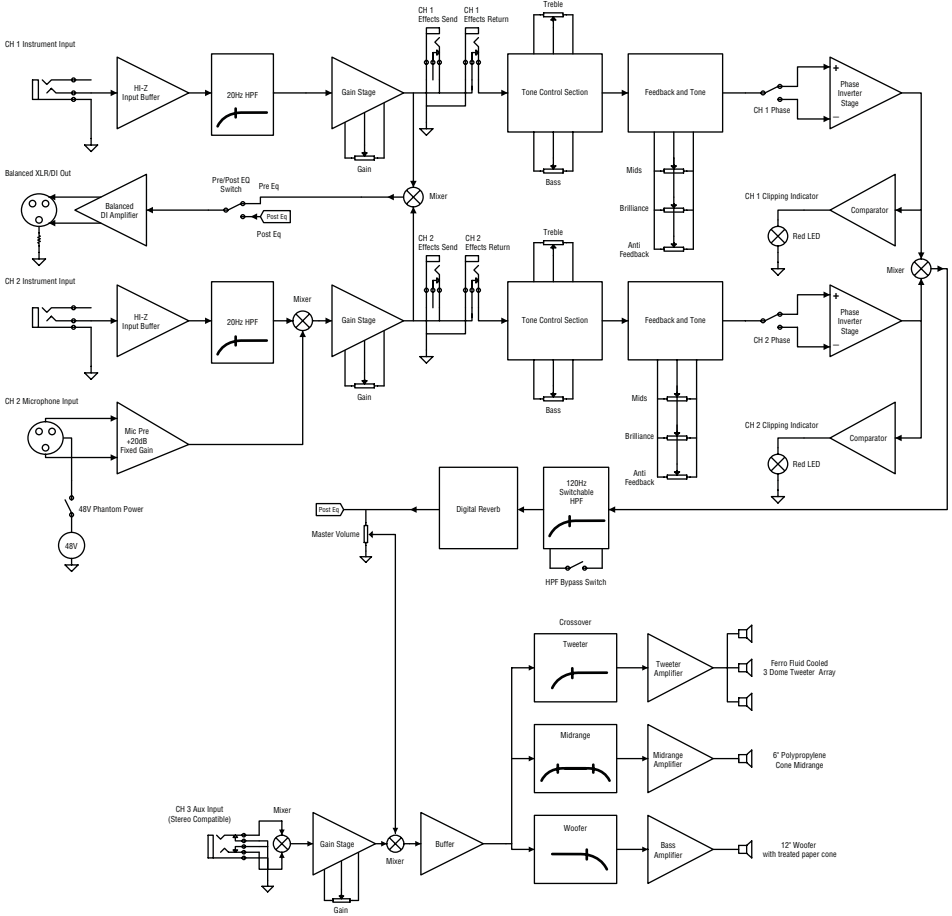

Limited Warranty

Save your original sales receipt. It is your proof of purchase if you require warranty service.

Fishman Acoustic Instrument Amplifiers ("Products") are warranted to the original consumer purchaser to be free of defects in materials and workmanship under normal use and service for a period of one (1) year from the date of purchase, with the exception of the speaker components, which are warranted for a period of ninety (90) days from the date of purchase. If the Product fails to function properly due to defects in materials or workmanship during the applicable warranty period, Fishman Transducers Inc. ("Fishman"), at its option, will repair or replace the Product, with no charge for labor or materials. This warranty applies only if the Product is sold and delivered within the U.S. by an authorized Fishman Dealer.

Warranty service and repairs for Fishman Acoustic Instrument Amplifiers are to be made only at an authorized Fishman Service Center OR at the factory in Wilmington MA. Unauthorized repairs will void this warranty.

Note: For factory warranty service, the customer must prepay freight to Fishman.

EXCEPT AS SPECIFICALLY PROVIDED IN THIS DOCUMENT, THERE ARE NO OTHER WARRANTIES, EXPRESSED OR IMPLIED, INCLUDING, BUT NOT LIMITED TO, IMPLIED WARRANTIES OF MERCHANTABILITY OR FITNESS FOR A PARTICULAR PURPOSE. IN NO EVENT SHALL FISHMAN BE LIABLE FOR LOSS OF PROFITS OR INCIDENTAL, INDIRECT, SPECIAL, CONSEQUENTIAL OR OTHER SIMILAR DAMAGES ARISING OUT OF ANY BREACH OF WARRANTY OR OTHER OBLIGATION CONTAINED IN THIS OWNERS' MANUAL. THE WARRANTY CONTAINED HEREIN SHALL NOT APPLY IF THE SERIAL NUMBER IS DEFACED OR REMOVED OR THE PRODUCT HAS BEEN DAMAGED BY ALTERATION, MISUSE, ACCIDENT, NEGLIGENCE OR USE WITH UNAUTHORIZED ATTACHMENTS.

To obtain warranty service from an authorized Fishman Service Center:

1. The Fishman Dealer where you purchased your amplifier may also be authorized to perform warranty service and should be your first point of contact. If the Fishman Dealer who sold the Product is authorized to service the amplifier, bring the defective unit to the service center along with your original sales receipt. If you can't provide the original receipt, the authorized Fishman Service Center may charge you for repairs.

If your local Fishman Dealer cannot service the amplifier, contact Fishman online via Service/Support at www.fishman.com and we will recommend an authorized Fishman Service Center in your area. If there is no service center close to you, return the amplifier to the factory as described below.

2. Make sure you can duplicate the problem for the Service Center. If you bring in the amplifier for warranty service and the technician can't duplicate the problem, you may be charged a service fee.
3. Fishman Authorized Service Centers reserve the right to inspect the amplifier before beginning warranty service. Final determination of warranty coverage lies solely with Fishman Transducers or its Authorized Service Centers.
4. Fishman assumes no responsibility for the quality or timeliness of repairs performed by Fishman Authorized Service Centers.

To obtain factory service:

Amplifiers repaired under warranty at the Fishman factory will be returned to the customer via UPS ground freight, prepaid by Fishman to any location within the continental United States.

Important!

A Product that is returned to Fishman which is not covered by the terms of this warranty will be repaired and returned C.O.D. with billing for labor, materials, return freight and insurance.

For factory service, you must deliver the amplifier prepaid freight to Fishman.

1. Contact Fishman Transducers Factory Service via Service and Support at www.fishman.com to obtain a Return Authorization number (RA number). Products returned without an RA number will be refused.
2. Pack the amplifier in its original shipping carton. If you do not have the carton, request one from us when you get your RA number. Include your shipping address (no P.O. boxes or route numbers). Also include a copy of your sales receipt and a note that explains how to duplicate the problem. If we cannot duplicate the problem at the Factory or verify the original purchase date, we may, at our option, charge for parts/labor and return shipping.
3. Ship the amplifier freight prepaid to:

***Fishman Transducers Service Department
340 Fordham Road, Wilmington, MA 01887 USA***

FISHMAN[®]

www.fishman.com

513-000-019 • Rev A • 6-10-04